

## POLYUNSATURATED FATTY ACIDS: FROM DIET TO BINDING TO PPARS AND OTHER NUCLEAR RECEPTORS

A. Bordoni, M. Di Nunzio, F. Danesi and P.L. Biagi

Centro Ricerche sulla Nutrizione - Department of Biochemistry "G. Moruzzi",  
University of Bologna Via Irnerio, 48 - 40126 Bologna, Italy

[Received April 7, 2006; Accepted June 21, 2006]

**ABSTRACT:** *Dietary polyunsaturated fatty acids (PUFAs) function not only by altering membrane lipid composition, cellular metabolism, signal transduction, but possess also effects on gene expression by regulating the activity/abundance of different nuclear transcription factors: peroxisome proliferator activated receptors, retinoid X receptors, liver X receptors, hepatic nuclear factors-4a, and sterol regulatory binding proteins 1 and 2. PUFAs regulate the expression of genes in various tissues, including the liver, heart, adipose tissue, and brain, playing a major role in carbohydrate, fatty acid, triglyceride, and cholesterol metabolism. Before binding to transcription factors, PUFAs must be absorbed in the intestine and delivered to cells, and then they must enter the cell and the nucleus. PUFA concentration within the cell depends on many different factors, and regulate their possibility to act as transcription modulators. The aim of this review is to summarize recent knowledge about PUFAs destiny from diet to nuclear factors binding, examining the different variables which can modulate their interaction with nuclear factors themselves and therefore their effect on gene expression.*

**KEY WORDS:** Gene Expression, Nuclear Receptors, Nutrigenomic, Polyunsaturated Fatty Acids

**Abbreviation used:** AA, Arachidonic Acid; ACS, AcylCoA Synthase; A-FABP, Adipose Fatty Acid-Binding Protein; ALA,  $\alpha$ -Linolenic Acid; CBP, CREB Binding Protein; CE, Cholesterol Ester; COX, Cyclooxygenase; CYP, Cytochrome P450; DHA, Docosahexaenoic Acid; EPA, Eicosapentaenoic Acid; FA, Fatty Acid; FAAR, Fatty Acid-Activated Receptor; FABP<sub>pm</sub>, Plasma Membrane Fatty Acid-Binding Protein; FACoA, Fatty Acyl-CoA; FAT, Fatty Acid Translocase; FATP, Fatty Acid Transport Protein; H-FABP, Heart Fatty Acid-Binding Protein; HNF-4a, Hepatic Nuclear Factors-4a; I-FABP, Intestinal Fatty Acid-Binding Protein; LA, Linoleic Acid; LCFA, Long Chain Fatty Acid; L-FABP, Liver Fatty Acid-Binding Protein; LPX, Lipooxygenase; LXR, Liver X

Receptor; LXRE, LXR Responsive Element; MAP kinase, Mitogen-Activated Protein kinase; NCoR, Nuclear Receptor Corepressor; NEFA, Non-Esterified Fatty Acid; ORF, Open Reading Frame; PBP, PPAR Binding Protein; PL, Phospholipid; PLA2, Phospholipase A2; PPAR, Peroxisome Proliferator Activated Receptor; PPRE, PPAR Response Element; PUFA, Polyunsaturated Fatty Acid; RA, Retinoic Acid; RAR, Retinoic Acid Receptor; RXR, Retinoid X Receptor; SL, Sphingolipid; SM, Sphingomyelin; SMRT, Silencing Mediator for Retinoid- and Thyroid-Hormone Receptor; SRC-1, Steroid Receptor Coactivator-1; SRE, Sterol Responsive Element; SREBP, Sterol Regulatory Binding Protein; TAG, Triacylglycerol

---

*Corresponding Author:* Dr. Alessandra Bordoni, Centro Ricerche sulla Nutrizione, Department of Biochemistry "G. Moruzzi" Via Irnerio, 48, 40126 Bologna, Italy; Fax: +39 051 2091235; E-mail: [alessandra.bordoni@unibo.it](mailto:alessandra.bordoni@unibo.it)

---

### INTRODUCTION

Although since long ago nutrition has clearly had a predominant role in health management, the mechanisms by which certain nutrients are essential for optimal health and for the prevention of human diseases have been elucidated only recently, and in some cases not completely. At the beginning of the 20th century two fatty acids (FAs), linoleic (C18:2n-6, LA) and  $\alpha$ -linolenic (C18:3n-3, ALA), were recognized as essential, and later on the positive effects of their elongated and desaturated derivatives, n-6 and n-3 polyunsaturated fatty acids (PUFAs), appeared clear. Prior to the '90s, it was commonly believed that PUFAs exerted their effects through changes at the level of membrane phospholipids (PLs) or through the production of signalling molecules such as eicosanoids. Only in 1992 Gottlicher et al. (Gottlicher et al., 1992) established the existence of nuclear receptors capable for binding FAs and thus affecting gene transcription.

Since the initial description of peroxisome-proliferator activated receptors (PPARs), a number of other transcription factors have

been identified as targets for regulation by FAs or their metabolites, including retinoid X receptor (RXR), hepatic nuclear factor 4 $\alpha$  (HNF-4 $\alpha$ ), liver X receptor  $\alpha$  and  $\beta$  (LXR $\alpha$  and  $\beta$ ), and sterol regulatory element binding protein-1c (SREBP-1c) (Clarke, 2004; Sampath and Ntambi, 2004).

While examining the effects of FAs on gene transcription, it is seldom considered that, before exerting their nuclear effects, they must be absorbed in the intestine and delivered to cells; then they must enter the cell and the nucleus, where they bind to nuclear factors as non-esterified fatty acids (NEFAs) or as acylCoAs. So, to understand the effect of FAs on gene transcription, it is important to consider what happens not only inside but also outside the nucleus.

### FROM DIET TO THE NUCLEUS

Since dietary components interact first with the gastrointestinal tract, the mechanisms which regulate the bioavailability (degree or rate at which a substance is absorbed or become available at the site of physiological activity) of a nutritional molecule is fundamental to understand its bioactive role throughout the body. The gastrointestinal tract is a very complex organ, and many factors such as pH, motility, different microbial community, diet composition may influence the bioavailability of a substance (Schneeman, 2002). Although in physiological conditions lipids possess a good bioavailability, their absorption is influenced by so many factors that the plasma concentration of specific FAs after the consumption of a meal is not easily predictable.

The quantitatively most important lipid component in the human diet is triacylglycerol (TAG), which may amount to 100 g per day or more. The fatty acyl groups in dietary TAGs may vary in chain length from C2 to C24 and from saturated fatty acids to unsaturated fatty acids with up to six double bonds. The structure and fatty acid composition of TAGs affect their absorption and the distribution of the fatty acids in the body following digestion and absorption (Mu and Porsgaard, 2005). Furthermore, little is known about the influence of genetic polymorphisms on nutrient absorption, but an association between plasmatic NEFAs and polymorphism of intestinal fatty acid binding proteins (I-FABPs) has been suggested (Pratley et al., 2000).

Long chain fatty acids (LCFAs) are bound by I-FABPs, which transport them in the cytoplasm of columnar absorptive epithelial cells of the small intestine (Darimont et al., 2000). LCFAs absorption is influenced by a polymorphism at codon 54 of the I-FABP gene (Ala54Thr). These polymorphism results in a change from alanine to threonine, and is associated with a higher affinity of I-FABP in LCFA binding (Baier et al., 1995); Pima Indians homozygous for the Thr54 allele have higher plasmatic concentration of NEFAs after the consumption of a high fat meal (Pratley et al., 2000). This finding indicates that polymorphism in genes encoding for intestinal transporters may modulate bioavailability of dietary components, and bioavailability, in its turn, may modulate the effects of nutrients.

**Figure 1. From diet to nucleus.**

Plasma non-esterified fatty acids (NEFAs) derived from chylomicrons and VLDLs or mobilized from storage depots enter the cells via passive diffusion or transporters. Inside the cells, NEFAs are converted by acylCoA synthases to fatty acylCoAs (FACoAs), which are substrates for  $\beta$ -oxidation, desaturation/elongation and assimilation into complex lipids, i.e. cholesterol esters (CEs), triacylglycerols (TAGs), phospholipids (PLs) and sphingolipids (SLs). Both NEFAs and FACoAs regulate the activity/abundance of transcription factors. NEFAs released from PLs by phospholipase A2 (PLA2) are substrates for cyclooxygenase (COX), lipooxygenase (LOX) and cytochrome P450 (CYP). The resulting oxidized lipids can affect the activity of transcription factors.

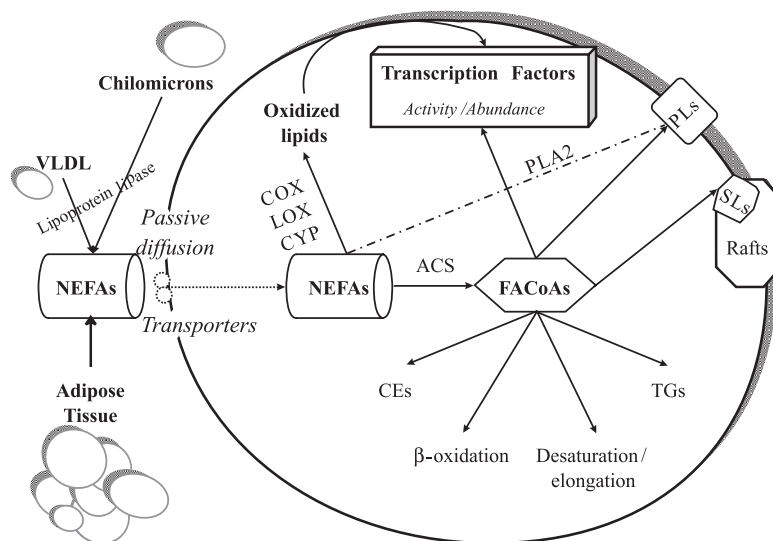

Once absorbed, FAs are reassembled in lipoprotein complexes and delivered to cells (figure 1). FAs esterified in chylomicron TAGs mainly come from dietary lipids, while those esterified in VLDL-TAGs derive from both diet and endogenous biosynthesis. In all cases, TAGs are hydrolysed by the action of lipoprotein lipase and NEFAs enter the cells, as well as circulating albumin-bound NEFAs mobilized from storage depots. While controversy still exists regarding the contribution of passive diffusion versus protein-mediated FA transport, both processes are now widely accepted. FAs cross the membrane by a purely diffusive process, without the requirement of protein mediators; different studies have suggested that diffusion is rapid enough to account for all FA transport (Pownall and Hamilton, 2003). On the other hand, many investigators believe that FA transport is mediated by specific membrane proteins via FA transporters.

Among these proteins are particularly: i. plasma membrane fatty acid-binding protein (FABP<sub>pm</sub>), an approximately 43 kDa protein located peripherally on the plasma membrane (Koonen et al., 2005); ii. fatty acid translocase (FAT)/CD36, an 88 kDa integral membrane glycoprotein, with two predicted transmembrane domains, which is identical to glycoprotein IV or CD36 of human blood platelets and leucocytes (Koonen et al., 2005); iii. fatty acid transport proteins 1-6 (FATP1-FATP6), which are differently expressed in different tissues (Kalant and

Cianflone, 2004). There are several recent reports on the regulation of proteins involved in FA transport, but how cells and tissues may regulate FA transporters under normal physiological conditions and in stress and disease is only beginning to be elucidated (Mashek and Coleman, 2006). Not surprisingly, factors activated by lipids or analogues often lead to modulation of FA transporters. These modes of regulation include transcriptional regulation through substrate-mediated stimulation such as PPAR activation or translocation from intracellular to plasma membrane compartments in the case of FAT/CD36 (Cameron-Smith et al., 2003) and FATP1 (Stahl, 2004).

Beyond the proteins that control FA entry into the cell, there are intracellular proteins that regulate partitioning to different metabolic fates, such as TAG synthesis for storage, PL synthesis, oxidation for energy, intracellular signalling, and protein acylation. These proteins include the acylCoA synthases (ACSs) and multiple small cytosolic proteins collectively termed fatty acid binding proteins (FABPs) (Hanhoff et al., 2002; Glatz et al., 2003).

Once in cells, NEFAs are rapidly converted to fatty acylCoA thioesters by ACS (figure 1). At least six ACS have been described, ACS-1 through ACS-5 and very long chain ACS (Coleman et al., 2000; Jump, 2002b); each isoform can activate a wide range of FAs, although some are most active toward specific FA (i.e. ACS-4 is most active with 20:4n6, 20:5n-3 and 22:6n-3) (Jump, 2002a). Recent studies suggest that certain ACS may channel acylCoA thioesters to specific metabolic compartments, for example ACS-1 and ACS-4 are linked to TAG synthesis (Lewin et al., 2001; Mashek and Coleman, 2006).

The conversion of NEFAs to acylCoA by ACS is a rate-determining step for entering of FAs into  $\beta$ -oxidation, elongation/desaturation or assimilation into complex lipids such as TAGs, cholesterol esters, or PLs. Sequestering into synthetic pathways such as lipid synthesis is also influenced by enzymes that “funnel” or “pull” FAs into these pathways.

A delay in assimilation of 20 and 22-carbon PUFAs into neutral lipids is due to the fact that CoA thioesters of 20 and 22-carbon PUFAs are poor substrates for many reactions; as examples, eicosapentaenoic acid (C20:5 n-3, EPA) but not arachidonic

(C20:4 n-6, AA) or docosapentaenoic acid (C22:5n-3), is a poor substrate for diacylglycerol acyltransferase, the terminal step in TAG biosynthesis (Madsen et al., 1999; Berge et al., 1999), and CoA thioesters of 20 and 22-carbon PUFAs are poor substrates for acylcholesterol acyltransferase I (Seo et al., 2001). Furthermore, PUFAs  $\geq 22$  carbons require prior peroxisomal  $\beta$ -oxidation to shorten the FA before entry into the mitochondrial  $\beta$ -oxidation spiral, this causing a delay in their oxidation (Sprecher, 2000). Taken all together these situations may lead to a rise in the intracellular NEFA or acylCoA levels of specific 20- and 22-carbon PUFAs (both n-6 and n-3). The intracellular concentration of NEFAs and acylCoA thioesters is low ( $< 10\mu\text{M}$ ), as most of them are protein bound (Jump, 2002a). FABPs are abundant cytosolic binding proteins having molecular masses of 14-15 kDa, characterised by their high affinity for hydrophobic molecules and their tertiary structures (Glatz et al., 2002). At present, nine types of FABPs are known and each of them has an overlapping but somewhat different substrate specificity, and each is encoded by a specific gene under cell type regulation of transcription (for a review, see Chmurzyńska, 2006). Liver-FABP (L-FABP) is mainly expressed in the liver and intestine, intestine-FABP (I-FABP) in the intestine, heart-FABP (H-FABP) in the heart, muscle, brown adipose tissue, prostate and placental trophoblast, and adipose-FABP (A-FABP) in white adipose tissue. L-FABP, I-FABP and H-FABP mRNAs are induced by PPAR $\alpha$  agonists, while A-FABP is induced by PPAR $\gamma$  agonists (Tontonoz et al., 1994). Unbound NEFAs and acylCoA binds to affect the activity of specific transcription factors; among them, PPARs are considered those mainly involved in direct PUFA regulation of gene expression.

**Table 1. Natural ligands of PPARs**

LIGAND	KD	REFERENCE
Palmitic acid, stearic acid	2-3 nM	Hostetler et al., 2005
Linoleic acid	$\cong 5$ nM	Lin et al., 1999
Linolenic acid	$\cong 8$ nM	Lin et al., 1999
Arachidonic acid	15-20 nM	Lin et al., 1999
Eicosapentaenoic acid	n.d.	
Docosahexaenoic acid	n.d.	
AcylCoA	1-4 nM	Hostetler et al., 2005
PGA <sub>1</sub> , PGA <sub>2</sub> , PGB <sub>3</sub> , PGD <sub>3</sub> , PGE <sub>3</sub> , PGF <sub>1<math>\alpha</math>'</sub> , PGF <sub>2<math>\alpha</math>'</sub> , PGF <sub>3<math>\alpha</math>'</sub> , PGI <sub>3</sub>	$> 1000 \mu\text{M}$	Ferry et al., 2001
PGA <sub>3</sub>	$\cong 180$	Ferry et al., 2001
PGB <sub>1</sub> , PGB <sub>2</sub> , PGD <sub>1</sub> , PGD <sub>2</sub> , PGE <sub>1</sub> , PGE <sub>2</sub> , PGF <sub>2<math>\beta</math>'</sub> , PGG <sub>2</sub> , PGE <sub>2</sub> , PGJ <sub>2</sub>	$< 100$	Ferry et al., 2001
PGH <sub>1</sub> , PGH <sub>2</sub>	$< 10$	Ferry et al., 2001
15-deoxy- $\Delta^{12,14}$ -prostaglandin J <sub>2</sub>	325 nM - 2.5 $\mu\text{M}$	Nosjean and Boutin, 2002
Leukotriene B <sub>4</sub>	submicromolar range	Devchand et al., 1996

PPAR ligands may be classified in synthetic ligands, such as peroxisome proliferators, hypolipidemic, anti-inflammatory and insulin-sensitizing compounds, and in natural ligands. The main natural PPAR ligands are reported in the table, together with their Kd value, when determined. n.d. = not determined.

**Figure 2. Structure and splice variants of the PPARs.**

A. The three PPAR isoforms share a similar modular structure with functionally distinct domains which is typical to members of the nuclear receptor superfamily. The N-terminal A/B domain mediates ligand-independent transcriptional activation (AF-1); the C domain contains the DNA-binding domain comprehensive of a two zinc-finger motif; the D domain is a hinge region; the E domain is the ligand binding domain, which contains the ligand-dependent transactivation function called (AF-2) and also offers the main surfaces for dimerization as well as for interaction with regulatory proteins called cofactors. B. Each PPAR family member is transcribed from a specific gene. Alternative splicing and the use of different promoters give rise to different splice variants. In humans, in addition to the full length mRNA for PPAR $\alpha$ , a splice variant lacking the hinge region (playing a role in receptor dimerization) and the entire ligand binding domain has been identified. The four splice variants for PPAR $\delta$  give rise to one primary translation product. PPAR $\gamma_1$ ,  $\gamma_3$ , and  $\gamma_4$  yield the same protein product, PPAR $\gamma$ , including the untranslated exons A1 and A2, PPAR $\gamma_3$  containing the untranslated exon A2, and PPAR $\gamma_4$  containing only exon 1-6, which are common to all PPAR $\gamma$  subtypes. PPAR $\gamma_2$  contains the translated exon B1, so in humans the protein encoded by PPAR $\gamma_2$  has an additional 28 amino acids in the N-terminus.

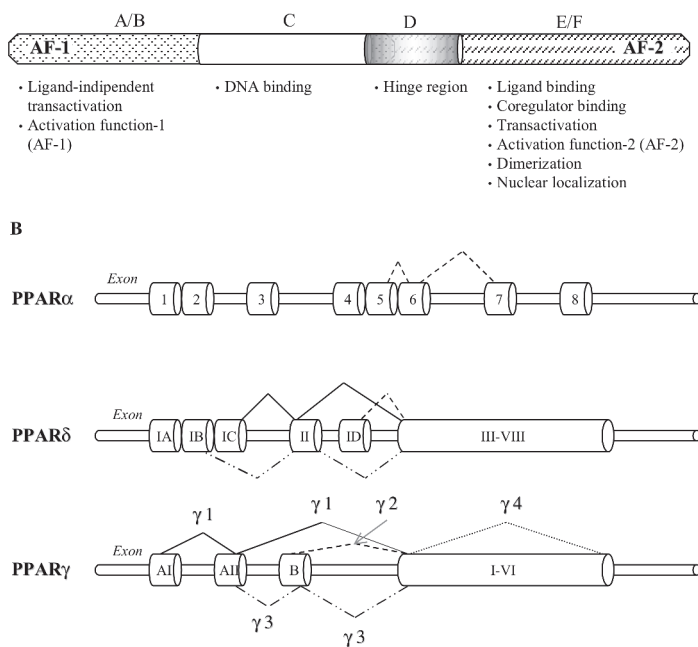

## INSIDE THE NUCLEUS: PEROXISOME-PROLIFERATOR ACTIVATED RECEPTORS (PPARs)

In 1990 PPARs were identified as transcription factors (Issemann and Green, 1990), and in 1992 Gottlicher et al. (Gottlicher et al., 1992) demonstrated that linoleic and arachidonic acid potently activate them. The three PPAR family members, PPAR $\alpha$  (NR1C1), PPAR $\delta$  [NUC-1, fatty acid-activated receptor (FAAR),  $\beta$ , NR1C2], and PPAR $\gamma$  (NR1C3), have a canonical nuclear receptor organization (figure 2A). The N-terminal A/B domain does not seem to be structured and harbors a weak ligand-independent transactivation function referred to as AF-1; the C domain contains the DNA-binding domain comprehensive of a two zinc-finger motif that is characteristic of the nuclear receptor superfamily; the D domain

is a hinge region. The E domain is the ligand binding domain and comprises 12 $\alpha$  helices and 4  $\beta$  sheets that fold to create a large hydrophobic cavity where ligands are buried. The E domain contains a ligand-dependent transactivation function called AF-2 and also offers the main surfaces for dimerization as well as for interaction with regulatory proteins called cofactors.

Each PPAR family member is transcribed from a specific gene. Alternative splicing and the use of different promoters give rise to different splice variants (figure 2B); in humans, in addition to the full length mRNA for PPAR $\alpha$ , a splice variant lacking the hinge region and the entire ligand binding domain, possibly interfering with PPAR and other nuclear receptors activity by competing for coactivators, has been identified (Gervois et al., 1999). The splice variants for PPAR $\delta$  give rise to one primary translation product (Larsen et al., 2002).

Structural studies of the PPAR- $\gamma$  gene and mRNA transcript support the existence of multiple PPAR- $\gamma$  isoforms. The open reading frame (ORF) of the PPAR- $\gamma$  gene consists of exons 1 to 6. Exons 2 and 3 encode the DNA binding domain, while exons 5 and 6 encode the ligand-binding domain. The 52-terminal region of the transcript is the most variable and is the determinant of the PPAR- $\gamma$  isoform. Until recently, three exons had been identified in the 52-terminal region in many species including rhesus monkey and human. They are referred to as exon A1, exon A2 and exon B. They are alternatively spliced with exons 1-6 of the ORF to generate three well established isoforms of PPAR- $\gamma$  as shown in figure 2B. PPAR- $\gamma_1$  consists of untranslated exon A1 and A2 spliced together with exons 1-6; the mRNA for PPAR- $\gamma_2$  consists of translated exon B and exons 1-6, so in humans the protein encoded by PPAR- $\gamma_2$  has an additional 28 amino acids in the N-terminus. A third isoform, PPAR- $\gamma_3$ , identified in humans, consists of only untranslated exon A2 in its 52-terminal region and exons 1-6; PPAR- $\gamma_4$  contains only exon 1-6, which are common to all PPAR- $\gamma$  subtypes.

Recently, Chen et al. (2006) identified two novel exons in PPAR- $\gamma$  cDNA from monkey macrophages, which have been called exon C and exon D. Both of these exons combine with either exons A1-A2 or with exon B to form novel PPAR- $\gamma$  isoforms.

PPAR $\alpha$  is expressed at relatively high levels in liver, small intestine, kidney, heart, and brown adipose tissue, and it is an important player in regulating FA transport and oxidation, cell proliferation, inflammatory crosstalk. PPAR $\delta$  is ubiquitously expressed and it is involved in development, lipid metabolism, proliferation of epidermal cells, myelination of nerves, wound healing (Tan et al., 2003), adaptive responses to exercise in skeletal muscle (Grimaldi, 2005). PPAR $\gamma$  plays a role in glucose homeostasis, lipid metabolism, cell cycle, inflammation, and carcinogenesis, and is an adipocyte differentiation factor (for a review, see Feige et al., 2006). The expression of the various PPAR $\gamma$  isoforms shows tissue specificity. PPAR $\gamma_1$  is the most widely expressed, PPAR $\gamma_2$  is localized primarily in adipocytes, PPAR $\gamma_3$  is

found in adipocytes, colonic epithelium, and macrophages, while the distribution of PPAR $\gamma$  is unclear (Sundvold and Lien, 2001; Ferre, 2004).

Among the multitude of agents that activate the PPARs, many have nutritional origin; for this reason it has been suggested that PPARs mediate dietary regulation of gene expression. Some specificity exist between ligands and the PPAR subtypes; structural and amino acid differences in the binding pocket of the PPAR isoforms contribute to selectivity for ligand binding (Xu et al., 2001a). PPAR ligands may be classified in synthetic ligands, such as peroxisome proliferators, hypolipidemic, anti-inflammatory and insulin-sensitizing compounds, and in natural ligands, such as medium- and long-chain fatty acids and eicosanoids (table 1). LCFAs, particularly PUFAs, preferentially activate PPAR $\alpha$  (Hostetler et al., 2005), but are also capable of activating PPAR $\delta$  and PPAR $\gamma$  (Desvergne and Wahli, 1999).

Among LCFAs, 18 and 20-carbon FAs are likely preferred ligands for PPAR activation (Jump, 2002a). Therefore activation of PPARs by 22-carbon FAs will likely require prior retroconversion to a 20-carbon PUFA, a process that requires peroxisomal  $\beta$ -oxidation. PPAR $\alpha$  binds 18:1n-9 and 20:5n-3 with nearly equal affinity (Xu et al., 1999a); notwithstanding, 20:5n-3 but not 18:1n-9 activates PPAR $\alpha$  in primary rat hepatocytes. The simplest explanation is that the intracellular NEFA pool available to activate PPAR $\alpha$  is subjected to metabolic regulation; since 20:5n-3CoA has been reported to be a poor substrate for TAG synthesis, the decrease in EPA assimilation into neutral lipids might elevate its intracellular concentration to a level sufficient to activate PPAR $\alpha$ .

Although LCFAs are thought to be putative endogenous PPAR $\alpha$  ligands, most radioligand binding studies demonstrated that PPAR $\alpha$  binds unsaturated LCFAs with only weak affinities ( $K_d$  values in the micromolar range) and saturated LCFAs (lauric and palmitic acids) are bound even less well (Forman et al., 1999). These radioligand-based affinities for LCFAs are several orders of magnitude weaker than PPAR $\alpha$  affinity for synthetic xenobiotics. Since nucleoplasmic LCFA concentrations are in the range of 39–68 nM (Huang et al., 2004), based on radioligand binding assays it would appear unlikely that LCFAs are physiologically significant endogenous ligands for PPAR $\alpha$ . Otherwise, PPAR binding pockets are 3–4 times larger than those of other nuclear receptors, being therefore large enough to allow different FAs to bind in multiple conformations (Blanquart et al., 2003). Flexible PUFAs are probably physiologically relevant ligands of PPARs even if they display lower affinity and activity compared to other compounds, and PPARs may function as lipid sensors and recognize a number of different metabolites rather than a single high-affinity hormone (Egea et al., 2002). Very recently, using direct fluorescence binding and fluorescence displacement assays, Hostetler et al. (2005) have provided significant evidence indicating that PPAR $\alpha$  exhibits high affinity (15–20 nM  $K_d$  values) for unsaturated (but not saturated) LCFAs. It is unclear whether only unsaturated LCFAs represent physiologically significant endogenous PPAR $\alpha$  ligands.

Nowadays, increasing data indicate that also LCFA metabolites such as LCFA-CoAs may represent active endogenous high affinity

PPAR $\alpha$  ligands (Hostetler et al., 2005). The observation of PPAR $\alpha$  high affinity for LCFA-CoAs and unsaturated LCFAs is in agreement with the structure of the ligand-binding pocket of this protein, which consists of 13  $\alpha$ -helices and four small  $\beta$ -strands, with the binding pocket forming a “Y”-shaped cavity of  $\sim 1400 \text{ \AA}^3$  (Xu et al., 1999a). This volume appears sufficient to accommodate LCFAs as well as LCFA-CoAs, which have typical volumes of  $<430 \text{ \AA}^3$  and  $<700 \text{ \AA}^3$ , respectively (Egea et al., 2002). The overall structure of the ligand-binding domain region of each PPAR subtype is very similar, with specific amino acid changes determining ligand specificity between the subtypes (Blanquart et al., 2003), suggesting that each PPAR subtype may interact with acyl-CoAs.

### Figure 3. PPAR binding to target genes.

PPARs exert their effect on gene transcription by dimerization with the 9, *cis*-retinoic acid receptors (RXRs). The heterodimer binds to a short sequence of DNA, the PPAR response element (PPRE) present in the promoter region of target genes. Many endogenous (table 1) and exogenous PPAR ligands are known; RXR is activated by 9, *cis*-retinoic acid, DHA and probably other polyunsaturated fatty acids. Different co activators and co repressors are supposed to play a role in PPAR regulation of target genes.

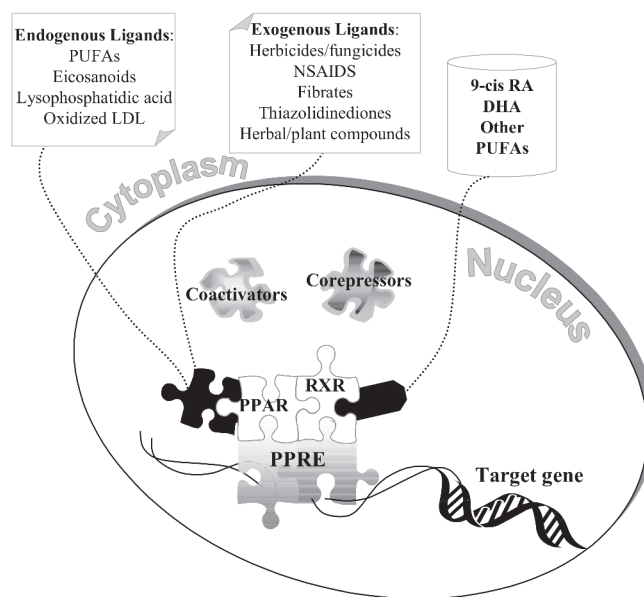

PPARs exert their effect on gene transcription by dimerization with the 9, *cis*-retinoic acid receptors (RXRs) (figure 3) (Feige et al., 2005). The heterodimer binds to a short sequence of DNA, the PPAR response element (PPRE) present in the promoter region of target genes, which is a DR1 sequence (direct repeat of the sequence AGGTCA, separated by one nucleotide) (Desvergne and Wahli, 1999). If the nucleotide between the two hexamers is an adenine, the binding affinity of the PPAR/RXR heterodimer is greatly enhanced. Also the presence of an AA/TCT sequence 5' of the PPRE increases affinity, since these DNA features result in a polarity to the bound heterodimer, PPAR binding to the

upstream hexamer while RXR interacting with the lower, 3' hexamer (Desvergne and Wahli, 1999).

RXRs bind the 9-*cis* isomer of retinoic acid (RA) only, while other nuclear receptors, retinoic acid receptors (RARs), bind both 9-*cis* and *all-trans* isomers (Shulman and Mangelsdor, 2005). RA derives from dietary vitamin A (retinol), which can be converted into retinal in cells. Retinal is the precursor of *all-trans* RA, which can be enzymatically isomerised to 9-*cis* RA. The regulation of this enzymatic step controls the 9-*cis*/*all-trans* ratio within the cell, regulating RAR and RXR pathways (Parker, 1996).

Although RXRs can be active as homodimers, the RXR heterodimers are the physiological relevant molecular species, and since RXR is the obligate partner with several other nuclear receptors, among which PPARs, it is a key receptor in many pathways. Another peculiarity of RXR is its propensity to form autorepressed homotetramer in the absence of ligands (Egea et al., 2001).

RXR is also able to bind FAs, and docosahexaenoic acid (DHA) has been shown to activate it (de Urquiza et al., 2000; Crawford et al., 2003). DHA deficiency in rat and humans results in abnormalities similar to those observed in RXR knock-out mice. The ability of RXR to bind FAs underlines its potential involvement in lipid homeostasis through complex feedback mechanisms in association with other nuclear receptors such as PPARs (Egea et al., 2002). Other PUFAs closely related to DHA, i.e. EPA or arachidonic acid, can activate RXR but with lower efficiency, while other FAs such as erucic acid (C20:1) fail to do it (Egea et al., 2002).

The conformational change that occurs upon ligand binding to PPARs also facilitates the recruitment of coactivators: steroid receptor coactivator-1 (SRC-1), CREB binding protein/p300 (CBP), RIP140, ARA70, members of the DRIP/TRAP family of coactivators, PPAR interacting protein, PPAR $\gamma$ coactivator-1, and PPAR binding protein (PBP). Similar to other steroid hormone receptors, there are also corepressors that associate with the PPARs: nuclear receptor corepressor (NCoR) and silencing mediator for retinoid- and thyroid-hormone receptors (SMRT), that dissociate from the receptor upon ligand binding (for a review, see Feige et al., 2006).

The activity of PPARs can be modified also by phosphorylation, nitration, ubiquitylation and sumoylation. The impact of phosphorylation on the activity of PPARs depends on the residue being phosphorylated, and the kinase cascade that has been activated (Gelman et al., 2005); nitration of tyrosine residues in PPAR $\gamma$  inhibits the translocation from the cytosol to the nucleus (Shibuya et al., 2002). Ligand binding to PPAR $\gamma$  induces ubiquitilation (Hauser et al., 2000), and therefore receptor degradation, while ligand binding to PPAR $\alpha$  stabilizes the receptor by decreasing its rate of ubiquitilation (Blanquart et al., 2002). Ligand binding also regulates sumoylation of PPAR $\gamma$ , which occurs on different lysine residue in a ligand-dependent or ligands-independent manner and exerts different effects (Ohshima et al., 2004). Ligands are therefore influencing PPAR activity in a very complex manner.

Although the identification of a PPRE in the promoter region is sometimes considered sufficient for considering a gene as a

PPAR-target gene, these stereotypic analyses is not sufficient to explain tissue-specific PPAR action. The basal expression of several genes is dominantly regulated in a tissue-specific manner, and not induced by a PPAR ligand alone even if that tissue abundantly expresses PPARs (Sato et al., 2002). This tissue specific PPAR action can be explained by two possibilities: i. the responsive gene is generally and dominantly repressed and PPAR/RXR alone cannot activate transcription without a tissue specific enhancing factor; ii. the gene is basically activated by PPAR/RXR alone but cells express a repressor.

PUFAs binding to PPAR $\alpha$  results in rapid upregulation of genes involved in lipid oxidation; in the meanwhile, PUFAs downregulate lipogenic genes, such as FA synthase. This downregulation is not mediated by PPAR $\alpha$ , since it has been shown also in PPAR $\alpha$  null mice, indicating that some effects of PUFAs are not mediated by PPAR $\alpha$  (Sampath and Ntambi, 2004). PPARs can mediate indirect repressive effects termed transrepression by inhibiting the activity of key transcription factors. Transrepression may occur either by inhibiting the binding of transcription factors to DNA through direct protein-protein interaction (tethering) or by sequestering cofactors necessary to their activity (squelching). Anyway, ligand binding is fundamental for PPAR repressive effects (Feige et al., 2006). Although the above mentioned mechanisms could explain a PPAR mediated repressive effects of PUFAs on gene expression, other transcription factors have been identified as possible mediators for PUFA-related downregulation of different genes.

## INSIDE THE NUCLEUS: PUFAs AND OTHER NUCLEAR RECEPTORS

### Liver X receptors (LXR $\alpha$ and LXR $\beta$ )

LXR $\alpha$  is found mainly in liver, kidneys, intestine, adipose tissue and adrenal glands, while LXR $\beta$  is more ubiquitarily expressed. Both LXRs bind oxysterols and directly regulate the expression of genes involved in hepatic bile acid synthesis. LXRs have also been shown to regulate genes involved in lipid metabolism such as lipoprotein lipase, fatty acid synthase, acetylCoA carboxylase and stearoylCoA desaturase 1. Furthermore, LXR indirectly regulate the expression of lipogenic genes through the regulation of SREBP-1c gene transcription (Zelcer and Tontonoz, 2006). LXR functions by heterodimerizing with RXR $\alpha$  and binding DR-4 repeats termed LXR response elements (LXREs). FAs work in different ways to antagonize the effects of LXRs in promoting lipid synthesis and storage:

- i. unsaturated FAs antagonize oxysterol binding to LXR $\alpha$  and inhibit LXR activation (Ou et al., 2001); the hierarchy for this effect is 20:4n-6 > 18:2n-6 > 18:1n-9. Saturated FAs have no effects.
- ii. FAs inhibit binding of the LXR $\alpha$ /RXR $\alpha$  heterodimers to the LXRE (Yoshikawa et al., 2002).
- iii. PPAR $\alpha$  and PPAR $\gamma$  that are activated by PUFAs have been shown to directly bind LXRs and antagonize their lipogenic effects probably by a competition between PPAR and LXR for the RXR partner (Yoshikawa et al., 2003). PPAR $\alpha$  activators induce transcription of the LXR $\alpha$ , but

not LXR $\beta$ , gene through cis-regulatory elements in the LXR $\alpha$  promoter. Thus PUFAs may potentially induce LXR $\alpha$  levels in cells, while inhibiting LXR $\alpha$  binding of oxysterols.

iv. binding of PUFAs to LXRs results in the inability of LXR to induce transcription of SREBP 1c, causing a consequent decrease in lipogenesis (Sampath and Ntambi, 2005).

### Hepatic nuclear factor-4 $\alpha$ (HNF-4 $\alpha$ )

HNF-4 $\alpha$  is a member of the hepatocyte nuclear factor family that includes six different isoforms (Hayhurst et al., 2001). It binds to DR1 elements as a homodimer and seems to be indispensable to hepatocyte differentiation and hepatic functions such as cholesterol and lipoprotein secretion. It is expressed mainly in liver, kidney, intestine, and pancreas and is capable of activating target genes even in the absence of ligand (Hayhurst et al., 2001).

A wide array of hepatic genes is controlled either directly or indirectly by HNF-4 $\alpha$ . These include the genes encoding apolipoproteins CII, CIII, AII, AIV, enzymes involved in iron and carbohydrates metabolism (L-pyruvate kinase, phosphoenolpyruvate carboxykinase), cytochrome P450, monooxygenases and bile acid synthesis (Hayhurst et al., 2001).

Fatty acylCoA thioesters at physiological concentrations can modulate the activity of HNF-4 $\alpha$  by directly binding to its ligand-binding domain. The effect of this binding seems to be dependent on factor such as chain length and degree of unsaturation of the FA. While binding of saturated FAs (14:0CoA or 16:0CoA) activate HNF-4 $\alpha$ , binding of 18:3n-3CoA, 20:5n-3CoA or 22:6n-3CoA results in repression of HNF-4 $\alpha$  (Sampath and Ntambi, 2004; Sampath and Ntambi 2005).

### Sterol regulatory element binding protein (SREBP)

SREBP are helix-loop helix transcription factors involved in the transcription of genes related to cholesterol and lipid synthesis. Three SREBP have been described; SREBP 1a and 1c are transcribed from the same gene locus, but they differ for the N-termini, SREBP1c being the predominant subtype expressed in rodents and humans; a separate gene encodes SREBP 2. SREBP 1 has emerged as a regulator of FA and TAG synthesis, while SREBP 2 regulates cholesterol synthesis (Osborne, 2000).

SREBPs are translated as large precursors tethered to the endoplasmic reticulum where SREBP is bound at the C-terminal end to SREBP cleavage activating protein. When cellular cholesterol levels are high, Insig proteins bind and trap SREBP cleavage-activating protein, retaining it in the endoplasmic reticulum and preventing it from escorting SREBPs from endoplasmic reticulum to the site of proteolytic activation in the Golgi complex (Yabe et al., 2003).

With sterol depletion, both SREBP and SREBP-cleavage activating protein move to the Golgi where proteases (site 1 protease and site 2 protease) cleave the protein to release a mature transcriptional form (nSREBP) that travels to the nucleus to bind to sterol regulatory elements in promoters of specific genes (Jump, 2002a).

SREBPs act on genes containing sequences called sterol responsive elements (SREs) in their promoter regions (Sampath

and Ntambi, 2004). SREBP-1c binds SREs in promoters of many genes involved in de-novo lipogenesis and TAG synthesis, including ATP-citrate lyase, acetylCoA- carboxylase, fatty acid synthase, stearoylCoA desaturase 1, glycerol phosphate acyl transferase; SREBP-2 upregulate genes involved in cholesterol synthesis.

Rats fed fat-free diets supplemented with n-3 and n-6 PUFAs showed decreased nuclear levels and expression of SRE-containing target genes (Xu et al., 1999b). SREBP may not bind FAs or cholesterol, instead, their effect on gene expression is determined by regulating the nuclear abundance of nSREBPs. Elevated intracellular cholesterol downregulates the site 1 protease, effectively reducing the formation of nSREBPs. Thus, cholesterol is a feed back regulator controlling SREBP nuclear level (Jump, 2002a). Cholesterol is not equally distributed in cells; most cholesterol is found in the plasma membrane, often associated with sphingomyelin (SM) (Worgall et al., 2002). SM typically contains saturated acyl chains and together with cholesterol it is found associated with lipid rafts. Treatment of cells with unsaturated FAs stimulates sphingomyelinase releasing ceramide as well as redistributing cholesterol from the plasma membrane to the endoplasmic reticulum. These events suppress proteolytic processing of the precursor of SREBP and result in a decline in nSREBP levels and SREBP-mediated gene expression. This mechanism does not affect mRNA encoding any SREBPs.

PUFAs reduce the nuclear content of SREBP-1c via a two phases mechanism. The first phase is rapid (<60 min) and consists in the above mentioned inhibition of the proteolytic release process (Hannah et al., 2001); the second one involves an adaptative (about 48 hours) reduction in the hepatic content of SREBP-1 mRNA that is subsequently followed by a reduction in the amount of precursor SREBP-1 protein (Xu et al., 2001b). Unsaturated FAs selectively suppress hepatic levels of the mRNA encoding SREBP-1 (both 1a and 1c), but not SREBP-2 (Mater et al., 1999; Yahagi et al., 1999); the hierarchy for FA regulation of mRNA<sub>SREBP-1c</sub> is 20:5n-3 = 20:4n-6 > 18:2n-6 > 18:1n-9. This effect may be attributed to inhibition of transcription of the SREBP-1 gene as well as enhanced turnover of the mRNA encoding SREBP-1; PUFAs reduce the half-life of SREBP-1c mRNA from 11 hours to <5hours (Xu et al., 2001b). Recently, Botolin et al. (2006) have demonstrated that 22:6n-3 accelerates the degradation of nSREBP-1 by a 26S proteasome-dependent pathway while having little impact on microsomal SREBP-1 or nSREBP-2.

### CONCLUSION

It is well documented that dietary fat regulates gene expression by controlling the activity/abundance of key transcription factors. PUFAs regulation of gene expression also accomplishes with modulation of mRNA processing, mRNA decay and stimulation of post translational protein modifications.

Moreover, there are alternative routes for PUFA regulation of transcription factor function, either through generation of alternative ligands or activation of kinase signalling cascade. For example, incorporation of PUFAs into membrane PLs affects

membrane fluidity and cholesterol content and impacts the generation of signalling molecules. Enrichment of PUFAs in membrane components associated with lipid rafts (both the PL and acylated protein components) has a significant impact on G-protein related receptors, Src kinase, mitogen-activated protein kinases (MAP kinases) and  $\text{Ca}^{2+}$  signalling. Mitogen-activated protein kinases phosphorylation of PPARs, SREBPs and HNF-4 $\alpha$  affect their activity. Elevation of PUFAs into membrane PLs also affects membrane cholesterol levels. Increased PUFA in PLs displaces cholesterol to the cytoplasm where it can affect microsomal processing of SREBP.

PUFAs also affect the synthesis of bioactive lipids generated by cyclooxygenases (COXs) 1 and 2, and 5, 12 and 15-lipoxygenases (LPXs). Both COX and LPXs products bind and affect the activity of PPARs, particularly PPAR $\gamma$ . Among PUFAs, EPA is not only a poor substrate for cyclooxygenases and lipoxygenases, in contrast to 20:4n-6, but in addition eicosanoids originating from it display weak activity as PPAR activators.

Independent of their mechanisms of action, an underlying assumption regarding fatty acid effects on gene expression is that they are absorbed and transported and that they enter the cells. Since many variables regulate intestinal absorption, transport and cellular uptake, FA cytosolic concentration may significantly differ among subjects and tissues. Furthermore, FA intracellular metabolism regulates FA uptake. In turn, metabolism requires intracellular transport and FA activation, which appears as a key step linking uptake and metabolism. FA activation, binding to cytosolic proteins and intracellular metabolism appear to be a driving force in regulating acylCoA and NEFA concentration inside the cell. How this regulation occur it is not known, but since it could be different in different cells and for different FAs, it could partially explain why different FAs do not have the same final effect in all tissues.

The nuclear actions of PUFAs is established in liver cells (Jump et al., 2005), in pancreas (Manco et al., 2004), immune system (Calder, 2003), brain (Uauy and Calderon, 2003), adipose tissue (Al-Hasani and Joost, 2005) and heart (Vanden Heuvel, 2004), and the possibility of counteracting human diseases by dietary FAs, particularly n-3 PUFAs, has been largely investigated, although their therapeutic effects are still unclear (De Caterina et al., 2006; Engler and Engler, 2006; Hooper et al., 2006; Lombardo and Chicco, 2006; Grynberg, 2005; Mills et al., 2005; Rodriguez-Cruz et al., 2005; Sekiya et al., 2003). It is important to remember that the effects of PUFAs are due to changes in membrane FA composition and subsequent alterations in hormonal signalling, as well as to their direct, membrane independent influence on molecular events that govern gene expression. Ongoing researches and those completed thus far has indeed established PUFAs as universal regulators of cellular metabolism and increased our understanding on the role that dietary fats play at cellular and nuclear levels. Studies on the molecular mechanism by which n-3 and n-6 PUFAs function could pave the way to finding novel targets for pharmacological treatment of various chronic diseases.

In this complex scenario, it is fundamental to underline that PUFA effects largely depend on PUFA cellular concentration;

up-to-date the dietary amount of n-6 and n-3 PUFAs and the best n-6 to n-3 ratio required for optimum metabolic benefit are unknown.

Future research should explore the real effectiveness of PUFAs in the prevention/counteraction of human diseases, designing studies that closely represent physiological conditions and taking into account all variables that could influence PUFA concentration within the different cells. Such researches will provide valuable insights into understanding the complexity of PUFA effects, and will be useful to educators and policy makers in setting recommendations for reaching optimal health through good nutrition.

## REFERENCES

- Al-Hasani, H. and Joost, H.G. (2005) Nutrition-/diet-induced changes in gene expression in white adipose tissue. *Best Practice & Research. Clinical Endocrinology & Metabolism* **19**, 589-603.
- Baier, L.J., Sacchettini, J.C., Knowler, W.C., Eads, J., Paolisso, G., Tataranni, P.A., Mochizuki, H., Bennett, P.H., Bogardus, C. and Prochazka, M. (1995) An amino acid substitution in the human intestinal fatty acid binding protein is associated with increased fatty acid binding, increased fat oxidation, and insulin resistance. *The Journal of Clinical Investigation* **95**, 1281-1287.
- Berge, R.K., Madsen, L., Vaagenes, H., Tronstad, K.J., Gottlicher, M. and Rustan, A.C. (1999) In contrast with docosahexaenoic acid, eicosapentaenoic acid and hypolipidaemic derivatives decrease hepatic synthesis and secretion of triacylglycerol by decreased diacylglycerol acyltransferase activity and stimulation of fatty acid oxidation. *The Biochemical Journal* **343**, 191-197.
- Blanquart, C., Barbier, O., Fruchart, J.C., Staels, B. and Glineur, C. (2002) Peroxisome proliferator-activated receptor alpha (PPARalpha) turnover by the ubiquitin-proteasome system controls the ligand-induced expression level of its target genes. *The Journal of Biological Chemistry* **277**, 37254-37259.
- Blanquart, C., Barbier, O., Fruchart, J.C., Staels, B. and Glineur, C. (2003) Peroxisome proliferator-activated receptors: regulation of transcriptional activities and roles in inflammation. *The Journal of Steroid Biochemistry and Molecular Biology* **85**, 267-273.
- Botolin, D., Wang, Y., Christian, B. and Jump, D.B. (2006) Docosahexaenoic acid (22:6,n-3) regulates rat hepatocyte SREBP-1 nuclear abundance by Erk- and 26S proteasome-dependent pathways. *Journal of Lipid Research* **47**, 181-192.
- Calder, P.C. (2003) N-3 polyunsaturated fatty acids and inflammation: from molecular biology to the clinic. *Lipids* **38**, 343-352.
- Cameron-Smith, D., Burke, L.M., Angus, D.J., Tunstall, R.J., Cox, G.R., Bonen, A., Hawley, J.A. and Hargreaves, M. (2003) A short-term, high-fat diet up-regulates lipid metabolism and gene

- expression in human skeletal muscle. *The American Journal of Clinical Nutrition* **77**, 313-318.
- Chen, Y., Jimenez, A.R. and Medh, J.D. (2006) Identification and regulation of novel PPAR-gamma splice variants in human THP-1 macrophages. *Biochimica et Biophysica Acta* **1759**, 32-43.
- Chmurzynska, A. (2006) The multigene family of fatty acid-binding proteins (FABPs): function, structure and polymorphism. *Journal of Applied Genetics* **47**, 39-48.
- Clarke, S.D. (2004) The multi-dimensional regulation of gene expression by fatty acids: polyunsaturated fats as nutrient sensors. *Current Opinion in Lipidology* **15**, 13-18.
- Coleman, R.A., Lewin, T.M. and Muoio, D.M. (2000) Physiological and nutritional regulation of enzymes of triacylglycerol synthesis. *Annual Review of Nutrition* **20**, 77-103.
- Crawford, M.A., Golfetto, I., Ghebremeskel, K., Min, Y., Moodley, T., Poston, L., Phylactos, A., Cunnane, S. and Schmidt, W. (2003) The potential role for arachidonic and docosahexaenoic acids in protection against some central nervous system injuries in preterm infants. *Lipids* **38**, 303-315.
- Darimont, C., Gradoux, N., Persohn, E., Cumin, F. and De Pover, A. (2000) Effects of intestinal fatty acid-binding protein overexpression on fatty acid metabolism in Caco-2 cells. *Journal of Lipid Research* **41**, 84-92.
- De Caterina, R., Zampolli, A., Del Turco, S., Madonna, R. and Massaro, M. (2006) Nutritional mechanisms that influence cardiovascular disease. *The American Journal of Clinical Nutrition* **83**, 421S-426S.
- de Urquiza, A.M., Liu, S., Sjoberg, M., Zetterstrom, R.H., Griffiths, W., Sjoval, J. and Perlmann, T. (2000) Docosahexaenoic acid, a ligand for the retinoid X receptor in mouse brain. *Science* **290**, 2140-2144.
- Desvergne, B. and Wahli, W. (1999) Peroxisome proliferator-activated receptors: nuclear control of metabolism. *Endocrine Reviews* **20**, 649-688.
- Devchand, P.R., Keller, H., Peters, J.M., Vazquez, M., Gonzalez, F.J. and Wahli, W. (1996) The PPARalpha-leukotriene B4 pathway to inflammation control. *Nature* **384**, 39-43.
- Egea, P.F., Mitschler, A. and Moras, D. (2002) Molecular recognition of agonist ligands by RXRs. *Molecular Endocrinology* **16**, 987-997.
- Egea, P.F., Rochel, N., Birck, C., Vachette, P., Timmins, P.A. and Moras, D. (2001) Effects of ligand binding on the association properties and conformation in solution of retinoic acid receptors RXR and RAR. *Journal of Molecular Biology* **307**, 557-576.
- Engler, M.M. and Engler, M.B. (2006) Omega-3 fatty acids: role in cardiovascular health and disease. *The Journal of Cardiovascular Nursing* **21**, 17-24.
- Feige, J.N., Gelman, L., Michalik, L., Desvergne, B. and Wahli, W. (2006) From molecular action to physiological outputs: peroxisome proliferator-activated receptors are nuclear receptors at the crossroads of key cellular functions. *Progress in Lipid Research* **45**, 120-159.
- Feige, J.N., Gelman, L., Tudor, C., Engelborghs, Y., Wahli, W. and Desvergne, B. (2005) Fluorescence imaging reveals the nuclear behavior of peroxisome proliferator-activated receptor/retinoid X receptor heterodimers in the absence and presence of ligand. *The Journal of Biological Chemistry* **280**, 17880-17890.
- Ferre, P. (2004) The biology of peroxisome proliferator-activated receptors: relationship with lipid metabolism and insulin sensitivity. *Diabetes* **53**, S43-S50.
- Ferry, G., Bruneau, V., Beauverger, P., Goussard, M., Rodriguez, M., Lamamy, V., Dromaint, S., Canet, E., Galizzi, J.P. and Boutin, J.A. (2001) Binding of prostaglandins to human PPARgamma: tool assessment and new natural ligands. *European journal of pharmacology* **417**, 77-89.
- Forman, B.M., Chen, J. and Evans, R.M. (1997) Hypolipidemic drugs, polyunsaturated fatty acids, and eicosanoids are ligands for peroxisome proliferator-activated receptors alpha and delta. *Proceedings of the National Academy of Sciences of the United States of America* **94**, 4312-4317.
- Gelman, L., Michalik, L., Desvergne, B. and Wahli, W. (2005) Kinase signaling cascades that modulate peroxisome proliferator-activated receptors. *Current Opinion in Cell Biology* **17**, 216-222.
- Gervois, P., Torra, I.P., Chinetti, G., Grotzinger, T., Dubois, G., Fruchart, J.C., Fruchart-Najib, J., Leitersdorf, E. and Staels, B. (1999) A truncated human peroxisome proliferator-activated receptor alpha splice variant with dominant negative activity. *Molecular Endocrinology* **13**, 1535-1549.
- Glatz, J.F., Luiken, J.J., van Bilsen, M. and van der Vusse, G.J. (2002) Cellular lipid binding proteins as facilitators and regulators of lipid metabolism. *Molecular and Cellular Biochemistry* **239**, 3-7.
- Glatz, J.F., Schaap, F.G., Binas, B., Bonen, A., van der Vusse, G.J. and Luiken, J.J. (2003) Cytoplasmic fatty acid-binding protein facilitates fatty acid utilization by skeletal muscle. *Acta Physiologica Scandinavica* **178**, 367-371.
- Gottlicher, M., Widmark, E., Li, Q. and Gustafsson, J.A. (1992) Fatty acids activate a chimera of the clofibrilic acid-activated receptor and the glucocorticoid receptor. *Proceedings of the National Academy of Sciences of the United States of America* **89**, 4653-4657.

- Grimaldi, P.A. (2005) Regulatory role of peroxisome proliferator-activated receptor delta (PPAR delta) in muscle metabolism. A new target for metabolic syndrome treatment? *Biochimie* **87**, 5-8.
- Grynberg, A. (2005) Hypertension prevention: from nutrients to (fortified) foods to dietary patterns. Focus on fatty acids. *Journal of Human Hypertension* **19**, S25-S33.
- Hanhoff, T., Lucke, C. and Spener, F. (2002) Insights into binding of fatty acids by fatty acid binding proteins. *Molecular and Cellular Biochemistry* **239**, 45-54.
- Hannah, V.C., Ou, J., Luong, A., Goldstein, J.L. and Brown, M.S. (2001) Unsaturated fatty acids down-regulate srebp isoforms 1a and 1c by two mechanisms in HEK-293 cells. *The Journal of Biological Chemistry* **276**, 4365-4372.
- Hauser, S., Adelmant, G., Sarraf, P., Wright, H.M., Mueller, E., and Spiegelman, B.M. (2000) Degradation of the peroxisome proliferator-activated receptor gamma is linked to ligand-dependent activation. *The Journal of Biological Chemistry* **275**, 18527-18533.
- Hayhurst, G.P., Lee, Y.H., Lambert, G., Ward, J.M. and Gonzalez, F.J. (2001) Hepatocyte nuclear factor 4alpha (nuclear receptor 2A1) is essential for maintenance of hepatic gene expression and lipid homeostasis. *Molecular and cellular biology* **21**, 1393-1403.
- Hooper, L., Thompson, R.L., Harrison, R.A., Summerbell, C.D., Ness, A.R., Moore, H.J., Worthington, H.V., Durrington, P.N., Higgins, J.P., Capps, N.E., Riemersma, R.A., Ebrahim, S.B. and Davey Smith, G. (2006) Risks and benefits of omega 3 fats for mortality, cardiovascular disease, and cancer: systematic review. *BMJ* **332**, 752-760.
- Hostetler, H.A., Petrescu, A.D., Kier, A.B. and Schroeder, F. (2005) Peroxisome proliferator-activated receptor alpha interacts with high affinity and is conformationally responsive to endogenous ligands. *The Journal of Biological Chemistry* **280**, 18667-18682.
- Huang, H., Starodub, O., McIntosh, A., Atshaves, B.P., Woldegiorgis, G., Kier, A.B. and Schroeder, F. (2004) Liver fatty acid-binding protein colocalizes with peroxisome proliferator activated receptor alpha and enhances ligand distribution to nuclei of living cells. *Biochemistry* **43**, 2484-2500.
- Issemann, I. and Green, S. (1990) Activation of a member of the steroid hormone receptor superfamily by peroxisome proliferators. *Nature* **347**, 645-650.
- Jump, D.B. (2002a) Dietary polyunsaturated fatty acids and regulation of gene transcription. *Current Opinion in Lipidology* **13**, 155-164.
- Jump, D.B. (2002b) The biochemistry of n-3 polyunsaturated fatty acids. *The Journal of Biological Chemistry* **277**, 8755-8758.
- Jump, D.B., Botolin, D., Wang, Y., Xu, J., Christian, B. and Demeure, O. (2005) Fatty acid regulation of hepatic gene transcription. *The Journal of Nutrition* **135**, 2503-2506.
- Kalant, D. and Cianflone, K. (2004) Regulation of fatty acid transport. *Current Opinion in Lipidology* **15**, 309-314.
- Koonen, D.P., Glatz, J.F., Bonen, A. and Luiken, J.J. (2005) Long-chain fatty acid uptake and FAT/CD36 translocation in heart and skeletal muscle. *Biochimica et Biophysica Acta* **1736**, 163-180.
- Larsen, L.K., Amri, E.Z., Mandrup, S., Pacot, C. and Kristiansen, K. (2002) Genomic organization of the mouse peroxisome proliferator-activated receptor beta/delta gene: alternative promoter usage and splicing yield transcripts exhibiting differential translational efficiency. *The Biochemical Journal* **366**, 767-775.
- Lewin, T.M., Kim, J.H., Granger, D.A., Vance, J.E. and Coleman, R.A. (2001) Acyl-CoA synthetase isoforms 1, 4, and 5 are present in different subcellular membranes in rat liver and can be inhibited independently. *The Journal of Biological Chemistry* **276**, 24674-24679.
- Lin, Q., Ruuska, S.E., Shaw, N.S., Dong, D. and Noy, N. (1999) Ligand selectivity of the peroxisome proliferator-activated receptor alpha. *Biochemistry* **38**, 185-190.
- Lombardo, Y.B. and Chicco A.G. (2006) Effects of dietary polyunsaturated n-3 fatty acids on dyslipidemia and insulin resistance in rodents and humans. A review. *The Journal of Nutritional Biochemistry* **17**, 1-13.
- Madsen, L., Rustan, A.C., Vaagenes, H., Berge, K., Dyroy, E. and Berge, R.K. (1999) Eicosapentaenoic and docosahexaenoic acid affect mitochondrial and peroxisomal fatty acid oxidation in relation to substrate preference. *Lipids* **34**, 951-963.
- Manco, M., Calvani, M. and Mingrone, G. (2004) Effects of dietary fatty acids on insulin sensitivity and secretion. *Diabetes, Obesity & Metabolism* **6**, 402-413.
- Mashek, D.G. and Coleman, R.A. (2006) Cellular fatty acid uptake: the contribution of metabolism. *Current Opinion in Lipidology* **17**, 274-278.
- Mater, M.K., Thelen, A.P., Pan, D.A. and Jump, D.B. (1999) Sterol response element-binding protein 1c (SREBP1c) is involved in the polyunsaturated fatty acid suppression of hepatic S14 gene transcription. *The Journal of Biological Chemistry* **274**, 32725-32732.
- Mills, S.C., Windsor, A.C. and Knight, S.C. (2005) The potential interactions between polyunsaturated fatty acids and colonic inflammatory processes. *Clinical and Experimental Immunology* **142**, 216-228.

- Mu, H. and Porsgaard, T. (2005) The metabolism of structured triacylglycerols. *Progress in Lipid Research* **44**, 430-448.
- Nosjean, O. and Boutin, J.A. (2002) Natural ligands of PPARgamma: are prostaglandin J(2) derivatives really playing the part? *Cellular Signalling* **14**, 573-583.
- Ohshima, T., Koga, H. and Shimotohno, K. (2004) Transcriptional activity of peroxisome proliferator-activated receptor gamma is modulated by SUMO-1 modification. *The Journal of Biological Chemistry* **279**, 29551-29557.
- Osborne, T.F. (2000) Sterol regulatory element-binding proteins (SREBPs): key regulators of nutritional homeostasis and insulin action. *The Journal of Biological Chemistry* **275**, 32379-32382.
- Ou, J., Tu, H., Shan, B., Luk, A., DeBose-Boyd, R.A., Bashmakov, Y., Goldstein, J.L. and Brown, M.S. (2001) Unsaturated fatty acids inhibit transcription of the sterol regulatory element-binding protein-1c (SREBP-1c) gene by antagonizing ligand-dependent activation of the LXR. *Proceedings of the National Academy of Sciences of the United States of America* **98**, 6027-6032.
- Parker, R.S. (1996) Absorption, metabolism, and transport of carotenoids. *The FASEB Journal* **10**: 542-551.
- Pownall, H.J. and Hamilton, J.A. (2003) Energy translocation across cell membranes and membrane models. *Acta Physiologica Scandinavica* **178**, 357-365.
- Pratley, R.E., Baier, L., Pan, D.A., Salbe, A.D., Storlien, L., Ravussin, E. and Bogardus, C. (2000) Effects of an Ala54Thr polymorphism in the intestinal fatty acid-binding protein on responses to dietary fat in humans. *Journal of Lipid Research* **41**, 2002-2008.
- Rodriguez-Cruz, M., Tovar, A.R., del Prado, M. and Torres, N. (2005) Molecular mechanisms of action and health benefits of polyunsaturated fatty acids. *Revista de Investigación Clínica; Organo del Hospital de Enfermedades de la Nutrición* **57**, 457-472.
- Sampath, H. and Ntambi, J.M. (2004) Polyunsaturated fatty acid regulation of gene expression. *Nutrition Reviews* **62**, 333-339.
- Sampath, H. and Ntambi, J.M. (2005) Polyunsaturated fatty acid regulation of genes of lipid metabolism. *Annual Review of Nutrition* **25**, 317-340.
- Sato, O., Kuriki, C., Fukui, Y. and Motojima, K. (2002) Dual promoter structure of mouse and human fatty acid translocase/CD36 genes and unique transcriptional activation by peroxisome proliferator-activated receptor alpha and gamma ligands. *The Journal of Biological Chemistry* **277**, 15703-15711.
- Schneeman, B.O. (2002) Gastrointestinal physiology and functions. *The British Journal of Nutrition* **88**, S159-S163.
- Sekiya, M., Yahagi, N., Matsuzaka, T., Najima, Y., Nakakuki, M., Nagai, R., Ishibashi, S., Osuga, J., Yamada, N. and Shimano, H. (2003) Polyunsaturated fatty acids ameliorate hepatic steatosis in obese mice by SREBP-1 suppression. *Hepatology* **38**, 1529-1539.
- Seo, T., Oelkers, P.M., Giattina, M.R., Worgall, T.S., Sturley, S.L. and Deckelbaum, R.J. (2001) Differential modulation of ACAT1 and ACAT2 transcription and activity by long chain free fatty acids in cultured cells. *Biochemistry* **40**, 4756-4762.
- Shibuya, A., Wada, K., Nakajima, A., Saeki, M., Katayama, K., Mayumi, T., Kadowaki, T., Niwa, H. and Kamisaki, Y. (2002) Nitration of PPARgamma inhibits ligand-dependent translocation into the nucleus in a macrophage-like cell line, RAW 264. *FEBS Letters* **525**, 43-47.
- Shulman, A.I. and Mangelsdorf, D.J. (2005) Retinoid x receptor heterodimers in the metabolic syndrome. *The New England Journal of Medicine* **353**, 604-615.
- Sprecher, H. (2000) Metabolism of highly unsaturated n-3 and n-6 fatty acids. *Biochimica et Biophysica Acta* **1486**, 219-231.
- Stahl, A. (2004) A current review of fatty acid transport proteins (SLC27). *Pflügers Archiv: European Journal of Physiology* **447**, 722-727.
- Sundvold, H. and Lien, S. (2001) Identification of a novel peroxisome proliferator-activated receptor (PPAR) gamma promoter in man and transactivation by the nuclear receptor RORalpha1. *Biochemical and Biophysical Research Communications* **287**, 383-390.
- Tan, N.S., Michalik, L., Desvergne, B. and Wahli, W. (2003) Peroxisome proliferator-activated receptor (PPAR)-beta as a target for wound healing drugs: what is possible? *American Journal of Clinical Dermatology* **4**, 523-530.
- Tontonoz, P., Graves, R.A., Budavari, A.I., Erdjument-Bromage, H., Lui, M., Hu, E., Tempst, P. and Spiegelman, B.M. (1994) Adipocyte-specific transcription factor ARF6 is a heterodimeric complex of two nuclear hormone receptors, PPAR gamma and RXR alpha. *Nucleic Acids Research* **22**, 5628-5634.
- Uauy, R. and Calderon, F. (2003) Long-chain polyunsaturated fatty acids in visual and neural development: cellular and molecular mechanisms. *Forum of nutrition* **56**, 71-73.
- Vanden Heuvel, J.P. (2004) Diet, fatty acids, and regulation of genes important for heart disease. *Current Atherosclerosis Reports* **6**, 432-440.
- Worgall, T.S., Johnson, R.A., Seo, T., Gierens, H. and Deckelbaum, R.J. (2002) Unsaturated fatty acid-mediated decreases in sterol regulatory element-mediated gene transcription are linked to

cellular sphingolipid metabolism. *The Journal of Biological Chemistry* **277**, 3878-3885.

Xu, H.E., Lambert, M.H., Montana, V.G., Parks, D.J., Blanchard, S.G., Brown, P.J., Sternbach, D.D., Lehmann, J.M., Wisely, G.B., Willson, T.M., Kliewer, S.A. and Milburn, M.V. (1999a) Molecular recognition of fatty acids by peroxisome proliferator-activated receptors. *Molecular Cell* **3**, 397-403.

Xu, H.E., Lambert, M.H., Montana, V.G., Plunket, K.D., Moore, L.B., Collins, J.L., Oplinger, J.A., Kliewer, S.A., Gampe, R.T. Jr, McKee, D.D., Moore, J.T. and Willson, T.M. (2001a) Structural determinants of ligand binding selectivity between the peroxisome proliferator-activated receptors. *Proceedings of the National Academy of Sciences of the United States of America* **98**, 13919-13924.

Xu, J., Nakamura, M.T., Cho, H.P. and Clarke, S.D. (1999b) Sterol regulatory element binding protein-1 expression is suppressed by dietary polyunsaturated fatty acids. A mechanism for the coordinate suppression of lipogenic genes by polyunsaturated fats. *The Journal of Biological Chemistry* **274**, 23577-23583.

Xu, J., Teran-Garcia, M., Park, J.H., Nakamura, M.T. and Clarke, S.D. (2001b) Polyunsaturated fatty acids suppress hepatic sterol regulatory element-binding protein-1 expression by accelerating transcript decay. *The Journal of Biological Chemistry* **276**, 9800-9807.

Yabe, D., Komuro, R., Liang, G., Goldstein, J.L. and Brown, M.S. (2003) Liver-specific mRNA for Insig-2 down-regulated by insulin: implications for fatty acid synthesis. *Proceedings of the National Academy of Sciences of the United States of America* **100**, 3155-3160.

Yahagi, N., Shimano, H., Hasty, A.H., Amemiya-Kudo, M., Okazaki, H., Tamura, Y., Iizuka, Y., Shionoiri, F., Ohashi, K., Osuga, J., Harada, K., Gotoda, T., Nagai, R., Ishibashi, S. and Yamada, N. (1999) A crucial role of sterol regulatory element-binding protein-1 in the regulation of lipogenic gene expression by polyunsaturated fatty acids. *The Journal of Biological Chemistry* **274**, 35840-35844.

Yoshikawa, T., Ide, T., Shimano, H., Yahagi, N., Amemiya-Kudo, M., Matsuzaka, T., Yatoh, S., Kitamine, T., Okazaki, H., Tamura, Y., Sekiya, M., Takahashi, A., Hasty, A.H., Sato, R., Sone, H., Osuga, J., Ishibashi, S. and Yamada, N. (2003) Cross-talk between peroxisome proliferator-activated receptor (PPAR) alpha and liver X receptor (LXR) in nutritional regulation of fatty acid metabolism. I. PPARs suppress sterol regulatory element binding protein-1c promoter through inhibition of LXR signaling. *Molecular Endocrinology* **17**, 1240-1254.

Yoshikawa, T., Shimano, H., Yahagi, N., Ide, T., Amemiya-Kudo, M., Matsuzaka, T., Nakakuki, M., Tomita, S., Okazaki, H., Tamura, Y., Iizuka, Y., Ohashi, K., Takahashi, A., Sone, H., Osuga, J., Gotoda, T., Ishibashi, S. and Yamada, N. (2002) Polyunsaturated

fatty acids suppress sterol regulatory element-binding protein 1c promoter activity by inhibition of liver X receptor (LXR) binding to LXR response elements. *The Journal of Biological Chemistry* **277**, 1705-1711.

Zelcer, N. and Tontonoz, P. (2006) Liver X receptors as integrators of metabolic and inflammatory signaling. *The Journal of Clinical Investigation* **116**, 607-614.